

400SCB/534 Speed Control Board

400 series Watson-Marlow Pumps

FEATURES AND BENEFITS

- Speed control ratio 20:1
- Remote facilities
- Compact design
- Optimised for 400FDC, 313/314FDP and 501FDP
- Mounted to the pump when ordered together
- Delivered with a remote potentiometer (10 Kohm)

These OEM motor speed controls are designed for operating permanent magnetic DC motors up to 30 watts. They are linear type controllers that provide smooth acceleration and deceleration under load, and a turndown of 20:1. Accepts AC or DC inputs.

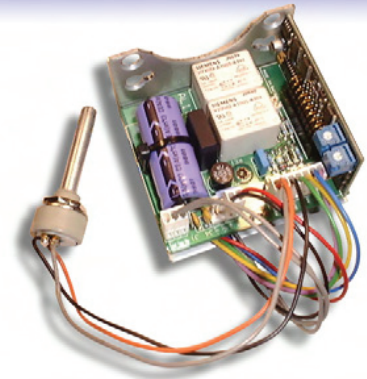

Watson-Marlow... Innovation in Full Flow

DIMENSIONS

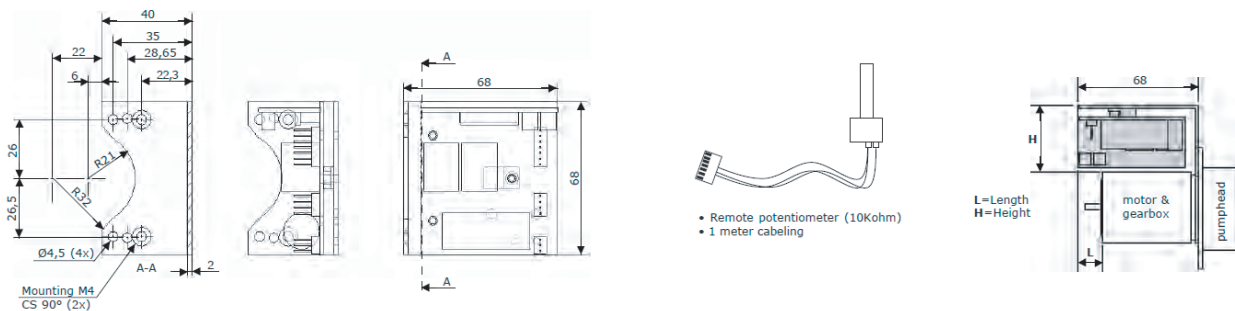

Assembled behind mounting panel with FDC and FDP drives			
	Length	Height	Width
FDC 5W motor with Ø40mm gearbox	-	2 x 1.5	40*
FDC/FDP 5W motor with Ø68mm gearbox	30	15	-
FDC/FDP 30W motor with Ø68mm gearbox	-	30	-

*Left or right, snapped together for transport only

TECHNICAL SPECIFICATION

400SCB/534	
Speed control ratio	20:1
Remote speed options	0-20mA or 4-20 mA, 0-1V or 0-10V, remote potentiometer (10Kohm)
Stop/Start	Remote switch or 5V logic
Direction	Remote switch or 5V logic
User adjustments	Max speed and signal selection
Temperature range	-30°C to 40°C
Supply voltage	15-30VDC or 12-22VAC 50/60Hz
Output voltage	0-12VDC or 0-24VDC
Recommended motors	Standard DC 5W, 12V or 30W, 24V (Economy DC 5W, 12V)

ORDER INFORMATION

400SCB/534			
Supply voltage	Output voltage	Motor	Product code
15-30VDC or 12-22VAC 50/60 Hz	0-12VDC or 0-24VDC	5W, 12V/30W, 24V	049.C534.000

All flow rates shown were obtained pumping water at 20C (68F) with zero suction and delivery heads. Watson-Marlow, Bioprene and Marprene are trademarks of Watson-Marlow Limited. Disclaimer: The information contained in this document is believed to be correct but Watson-Marlow Limited accepts no liability for any errors it contains, and reserves the right to alter specifications without notice. LoadSure is a trademark of Watson-Marlow Limited. © STA-PURE PFL and © STA-PURE PCS are registered trademarks of W.L Gore & Associates Inc. Please state the product code when ordering pumps and tubing.

**WATSON
MARLOW
Pumps**

wmftg.com
info@wmftg.com
+44 (0) 1326 370370